

正式图 参考图 设变图

REV.	ECN NO.	DESCRIPTION	DATE	DESIGN
AO	---	INITIAL RELEASED	2017.06.07	HAN MIN

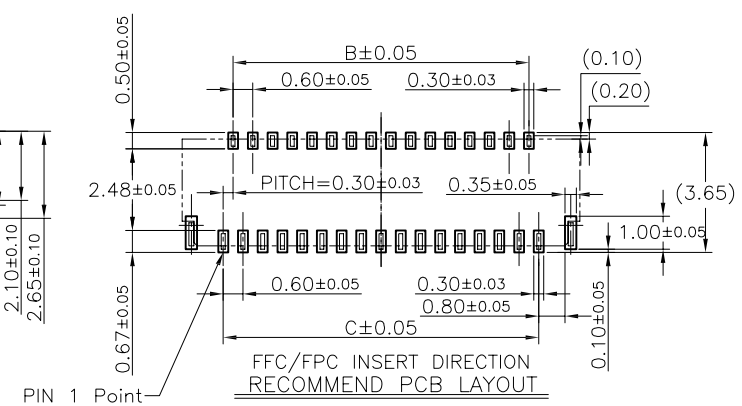
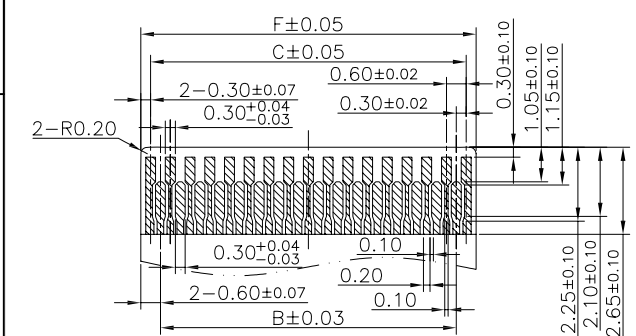
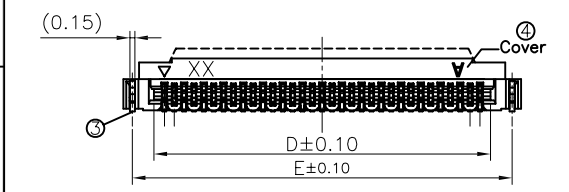
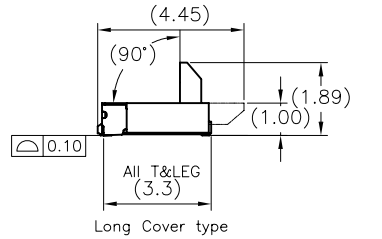
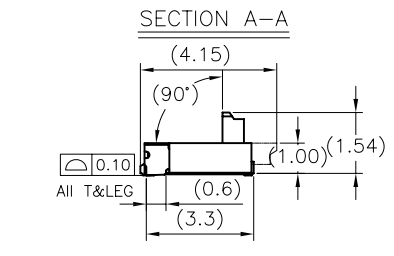
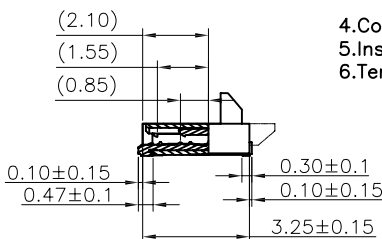
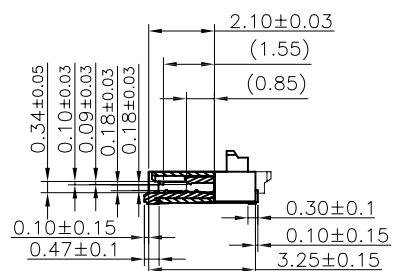
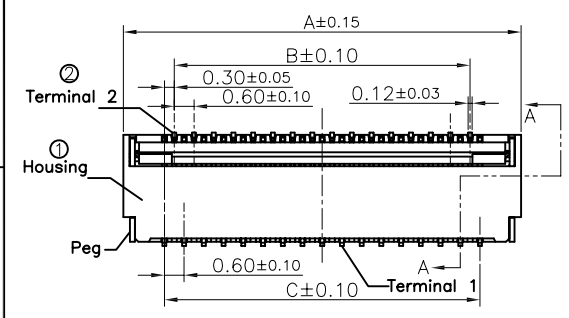

NOTE:
 1.Current Rating: 0.5A
 2.Rated voltage:50V AC\DC
 3.Dielectric Withstanding Voltage:
 AC 250V/1minute
 4.Contact resistance: ≤30mΩ
 5.Insulation resistance: ≥500MΩ
 6.Temperature range:
 -25°C to +85°C

Ordering information:
 FPO3200-XXP-DSXX-LP00X
 (1) (2) (3)
 (1):NO OF PIN :09P ~ 71P
 (2):Terminal plating:
 AE=Gold(G/F) A5=Semi gold Tin
 (3):Packing mode:
 3=Tube 4=Tape & Reel

PIN NO	DIM A	DIM B	DIM C	DIM D	DIM E	DIM F	NOTES
09	4.90	1.80	2.40	3.03	4.35	3.00	
11	5.50	2.40	3.00	3.63	4.95	3.60	
13	6.10	3.00	3.60	4.23	5.55	4.20	
15	6.70	3.60	4.20	4.83	6.15	4.80	
17	7.30	4.20	4.80	5.43	6.75	5.40	
19	7.90	4.80	5.40	6.03	7.35	6.00	
21	8.50	5.40	6.00	6.63	7.95	6.60	
23	9.10	6.00	6.60	7.23	8.55	7.20	
25	9.70	6.60	7.20	7.83	9.15	7.80	
27	10.30	7.20	7.80	8.43	9.75	8.40	
29	10.90	7.80	8.40	9.03	10.35	9.00	
31	11.50	8.40	9.00	9.63	10.95	9.60	
33	12.10	9.00	9.60	10.23	11.55	10.20	
35	12.70	9.60	10.20	10.83	12.15	10.80	
37	13.30	10.20	10.80	11.43	12.75	11.40	
39	13.90	10.80	11.40	12.03	13.35	12.00	
41	14.50	11.40	12.00	12.63	13.95	12.60	
43	15.10	12.00	12.60	13.23	14.55	13.20	
45	15.70	12.60	13.20	13.83	15.15	13.80	
47	16.30	13.20	13.80	14.43	15.75	14.40	
49	16.90	13.80	14.40	15.03	16.35	15.00	
51	17.50	14.40	15.00	15.63	16.95	15.60	
53	18.10	15.00	15.60	16.23	17.55	16.20	
55	18.70	15.60	16.20	16.83	18.15	16.80	Long Cove type
57	19.30	16.20	16.80	17.43	18.75	17.40	
59	19.90	16.80	17.40	18.03	19.35	18.00	
61	20.50	17.40	18.00	18.63	19.95	18.60	
63	21.10	18.00	18.60	19.23	20.55	19.20	
65	21.70	18.60	19.20	19.83	21.15	19.80	
67	22.30	19.20	19.80	20.43	21.75	20.40	
69	22.90	19.80	20.40	21.03	22.35	21.00	
71	23.50	20.40	21.00	21.63	22.95	21.60	

APPLICABLE FFC/FPC
 FFC/FPC THICKNESS=0.20±0.03

NO.	PART NAME	QTY.	MATERIAL	REMARK
④	COVER	1	LCP UL94V-0	Black
③	FITTING NAIL	2	Phosphor Bronze	Sn-plated
②	TERMINAL	N	Phosphor Bronze	See Ordering information
①	HOUSING	1	LCP UL94V-0	Natural

TOLERANCE	NAME(INTENDED USE)	ZHAOBO 浙江朝博电子有限公司 Zhejiang Zhaobo Electronic Co.,Ltd		
X.X ±0.30 X.* ±10°	CUSTOMER DRAWING	PART NO. See Ordering information		
.XX ±0.20 .X.* ± 8°				
.XXX ±0.10 .XX.* ± 5°		DESIGN: HAN MIN		
UNITS mm				
MATERILA ----	CHED: ZHU DE YIN	DRAWG NO. 03FP-0011		
FINISH ----	APPD: NI HAI QING			
		SCALE 1:1	SHEET 1/1	REV. AO